

TWS Bluetooth Earphone Charging Box SOC integrated with Qi wireless power receiver

1. Features

- **Discharge**
 - ◇ Output capacity: 5V/300mA
 - ◇ Up to 93%@5V/150mA discharge efficiency of synchronous switch
 - ◇ Built-in power path management supports charging and discharging at the same time
- **Charge**
 - ◇ Max 500mA linear charger, adjustable charging current
 - ◇ Adjusts charging current automatically to adapt to different load capacity adapters
 - ◇ Supports 4.20V, 4.30V 4.35V, 4.40V batteries
 - ◇ Supports wireless power receiver compliant with Qi
- **Battery indicators**
 - ◇ Built-in 12bits ADC , accurate calculation of battery capacity
 - ◇ Supports 4/3/2/1 LED battery indicator
- **Serial communication**
 - ◇ Double UART, support earphone independent communication function
- **Low-power dissipation**
 - ◇ Automatically detect earphone plugged-in/plugged-out/charger-end, Automatically enter standby mode
 - ◇ Support detection of earphone plug-in/plug-out independly
 - ◇ Standby power consumption up to 20uA minimum
- **Simplified BOM**
 - ◇ Built-in power MOS, only a few peripheral devices are needed in the complete charging and discharging scheme
- **Multiple protection, high reliability**
 - ◇ Output: over current and short circuit protection
 - ◇ Input: over voltage and Battery over charged protection
 - ◇ Over temperature protection
 - ◇ Vin pin can withstand up to 15V(transient

voltage)

- ◇ ESD 4KV

- **In-depth customization**
 - ◇ Flexible and low-cost customized program
- **Package: QFN24 (4*4*0.75mm)**

2. Applications

- TWS Bluetooth Earphone Charging Box
- Lithium Battery Portable Device

3. Description

IP6818 is a multi-functional power management SOC for total solution on TWS Bluetooth Earphone Charging Box. It integrates with Qi wireless power receiver, 5V-boost converter, lithium battery charging management and battery level indicators.

IP6818 is highly integrated with abundant functions, which makes the total solution size minimized and BOM costed down.

The synchronous 5V-boost system of IP6818 provides rated 300mA output current with conversion efficiency up to 93%. DC-DC converter operates at 1.5MHz, and can support low-cost inductors and capacitors.

IP6818's linear charging system supplies max 500mA charging current. With the change of IC temperature and input voltage, IP6818 can automatically adjust the charging current.

IP6818 can detect the TWS earphone plug-in/plug-out in the Charging Box independently. While the earphone is put in the Charging Box, it enters the discharging mode automatically. When the earphone is fully charged, the Charging Box automatically enters the sleep state, and the standby current can be reduced to 20uA. The earphone's charge-end current can be Flexible and customizable, such as 4mA or 8mA.

IP6818 can support 1/2/3/4 LED battery indicator, The built-in 12bits ADC can accurately calculate the Charging Box's battery capacity.

IP6818 is packaged with QFN24(4*4*0.75mm).

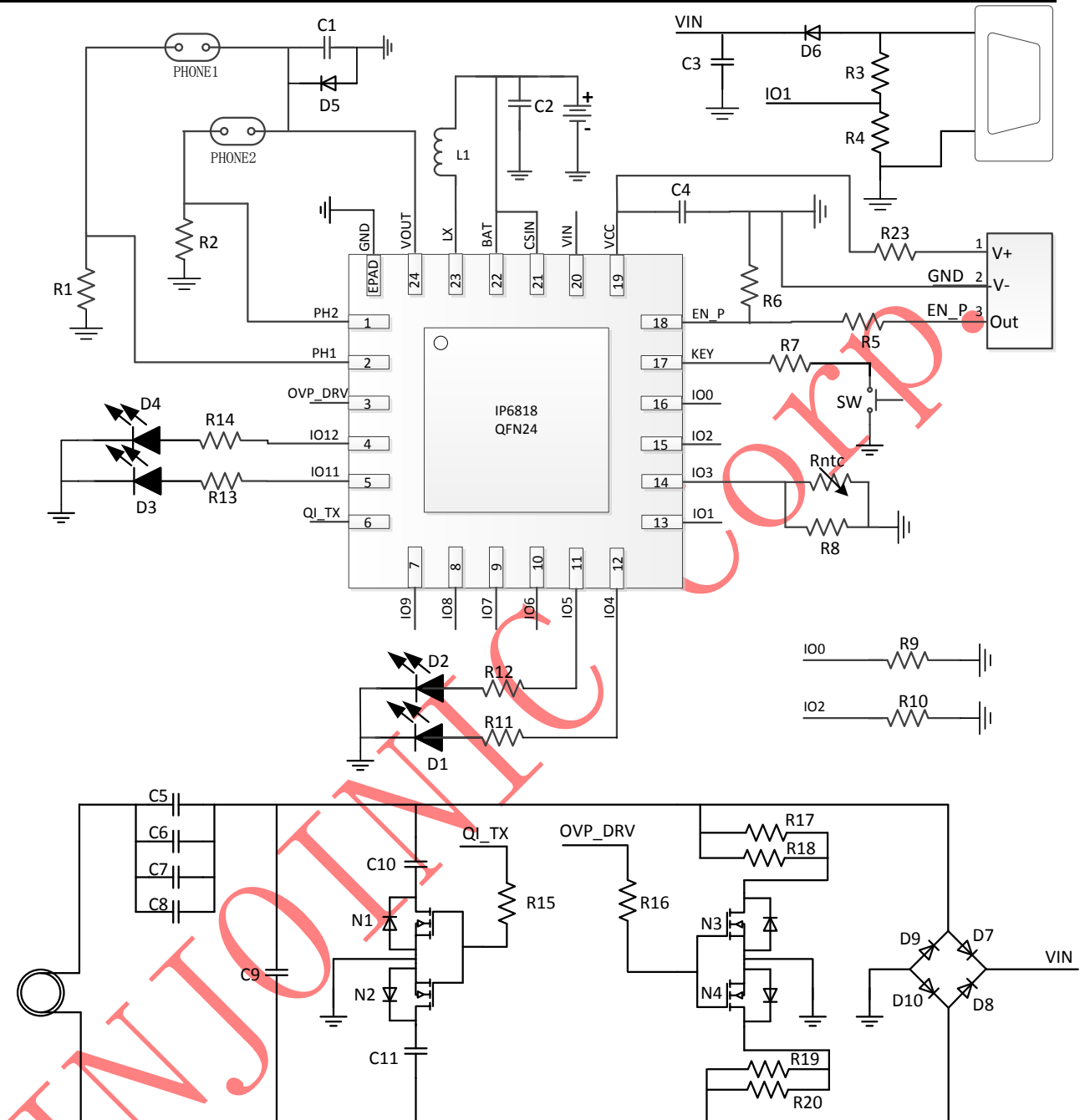

Figure1 IP6818 Simplified Application Diagram

4. Pin Definition

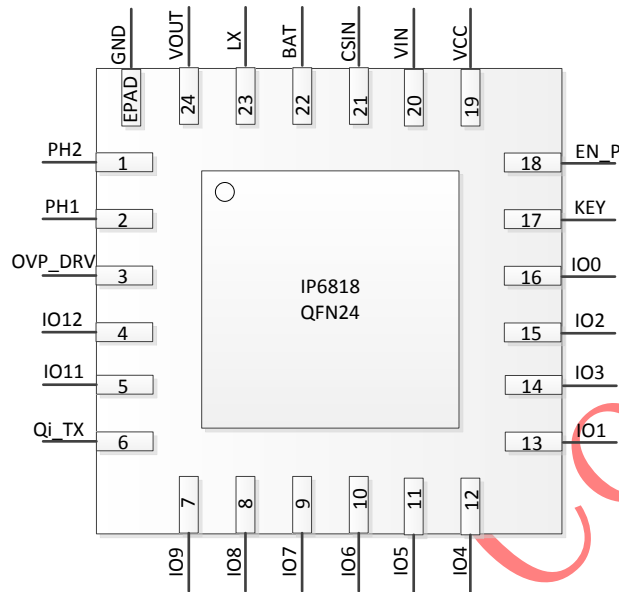

Figure 2 IP6818 Pin Assignments

PIN NUM	PIN NAME	Description
1	PH2	Earphone 2 negative
2	PH1	Earphone 1 negative
3	OVP_DRV	Overvoltage protection switch signal for wireless charging RX
4	IO12	IO12, can be reused as breathing light
5	IO11	IO11, can be reused as breathing light
6	Qi_TX	Wireless charging RX code sending pin
7	IO9	IO9, can be reused as UART0_TX
8	IO8	IO8, can be reused as UART1_TX
9	IO7	IO7, can be reused as UART0_RX
10	IO6	IO6, can be reused as UART1_RX
11	IO5	IO5, LED driver
12	IO4	IO4, LED driver
13	IO1	IO1, Identification of wired and wireless charging
14	IO3	IO3, NTC function
15	IO2	IO2, Wireless charging RX parameter adjustment 1
16	IO0	IO0, Wireless charging RX parameter adjustment 2
17	KEY	KEY
18	EN_P	Hall switch input signal, pull down by default. .
19	VCC	LDO output pin must be connected to a 2.2uF capacitor to ground.
20	VIN	5V input pin
21	CSIN	Battery voltage positive pin

22	BAT	Battery voltage positive pin
23	LX	DCDC switch node
24	VOUT	Boost output
Epad	GND	System GND

INJOINIC Corp.

5. IP Series Products List

	IC Part No.	LED Mode	Charging Current	Light-Load time	Key mode	Light-Load Current to enter standby	auto-wakeup supporting	always-5V supporting	Minimum order quantity
IP5303T series	IP5303T_BT_200MA	1/2	200mA	32 seconds	single start, double close	5mA	yes	no	4K
	IP5303T_BT_500MA	1/2	500mA	32 seconds	single start, double close	5mA	yes	no	4K
	IP5303T_500MA_S_NAT	1/2	500mA	32 seconds	single start, double close	5mA	no	no	4K
IP5305T series	IP5305T_BT	1/2/3/4	1A	32 seconds	single start, double close	5mA	yes	no	4K
	IP5305T_BT_500MA	1/2/3/4	500mA	32 seconds	single start, double close	5mA	yes	no	4K
	IP5305T_BT_300MA	1/2/3/4	300mA	32 seconds	single start, double close	5mA	yes	no	4K
	IP5305T_BT_8S	1/2/3/4	1A	8 seconds	single start, double close	5mA	yes	no	4K
	IP5305T_BT_8S_300MA	1/2/3/4	300mA	8 seconds	single start, double close	5mA	yes	no	4K
IP5403 series	IP5403_CK10_5M	4	500mA	36 seconds	single start, no key close	10mA	no	yes	4K
	IP5403_CK10_5M_D1D2	1/2	500mA	36 seconds	single start, no key close	10mA	no	yes	4K
	IP5403_CK10_2M	4	200mA	36 seconds	single start, no key close	10mA	no	yes	4K
	IP5403_CK10_2M_D1D2	1/2	200mA	36 seconds	single start, no key close	10mA	no	yes	4K
	IP5403_BT10_5M	4	500mA	36 seconds	single start, no key close	10mA	no	no	4K
	IP5403_BT10_5M_D1D2	1/2	500mA	36 seconds	single start, long close	10mA	no	no	4K
	IP5403_BT10_2M	4	200mA	36 seconds	single start, long close	10mA	no	no	4K
	IP5403_BT10_2M_D1D2	1/2	200mA	36 seconds	single start, long close	10mA	no	no	4K

6. Absolute Maximum Ratings

Parameter	Symbol	Value	Unit
Input Voltage Range	V_{IN}	-0.3 ~ 15	V
Junction Temperature Range	T_J	-40 ~ 150	°C
Storage Temperature Range	T_{stg}	-60 ~ 150	°C
Thermal Resistance (Junction to Ambient)	θ_{JA}	50	°C/W
ESD (Human Body Model)	ESD	4	KV

*Stresses beyond these listed parameter may cause permanent damage to the device.

Exposure to Absolute Maximum Rated conditions for extended periods may affect device reliability.

7. Recommended Operating Conditions

Parameter	Symbol	Min.	Typ.	Max.	Unit
Input Voltage	V_{IN}, V_{BUS}	4.5	5	6.0	V
Operating Temperature	T_A	0	--	70	°C

*Devices' performance cannot be guaranteed when working beyond those Recommended Operating Conditions.

8. Electrical Characteristics

Unless otherwise specified, TA=25°C, L=1uH

Parameter	Symbol	Test Conditions	Min.	Typ.	Max.	Unit
Charging System						
USB Input Voltage	V _{USB}	V _{BAT} =3.7V	4.5	5	6.0	V
Wireless RX Input Voltage	V _{INRX}	V _{BAT} =3.7V	4.5	5.2	12	V
VIN activation voltage	V _{INOk}		3.0	3.2	3.4	V
Input Under Voltage	V _{INUV}		4.0	4.2	4.4	V
Constant Charge Voltage	CV _{4.2V}	Different CV voltage needs to be customized, the default is CV4.2V	4.15	4.20	4.24	V
	CV _{4.30V}		4.28	4.30	4.34	V
	CV _{4.35V}		4.33	4.35	4.4	V
	CV _{4.4V}		4.38	4.40	4.44	V
Charge Stop Current	I _{vinstop}	V _{IN} =5V	10	15	20	mA
Charge Current	I _{VIN}	V _{IN} =5V, V _{BAT} =3.7V, Set the charge current=300mA	260	300	340	mA
Trickle Charge Current	I _{TRKL}	V _{IN} =5v, BAT=2.7v	20	25	30	mA
Trickle Charge Stop Voltage	V _{TRKL}		2.9	3	3.1	V
Recharge Voltage Threshold	V _{RCH}		4.07	4.1	4.13	V
Charge Cut-Off Time	T _{END}		20	24	28	Hours
Boost System						
BatteryOperation Voltage	V _{BAT}		3.0	3.7	4.3	V
Low Power Shutdown Voltage	V _{BATLOW}	I _{OUT} =200mA	2.9	3.0	3.1	V
Switching battery input current	I _{BAT}	V _{BAT} =3.7V,V _{OUT} =5.0V, fs=1.5MHz(without LED indicator, V _{OUT} without load)		4	6	mA
DC Output Voltage	V _{OUT}	V _{BAT} =3.7V @0A	5.0	5.1	5.2	V
		V _{BAT} =3.7V @200mA	4.85	5.1	5.2	V
Output Voltage Ripple	ΔV _{OUT}	V _{BAT} =3.0V~4.4V	50	100	150	mV
Boost Output Current	I _{vout}	V _{BAT} =3.0V~4.4V	0		300	mA
Boost Overcurrent Shut	I _{shut}	V _{BAT} =3.0V~4.4V	0.7	0.8	0.9	A

Down Threshold						
Load Overcurrent Detect Time	T_{UVD}	Duration of output voltage under 4.2V		30		ms
Control System						
Switch Frequency	f_s	Discharge switch frequency	1.3	1.5	1.6	MHz
PMOS On Resistance	r_{DSON}			450		$m\Omega$
NMOS On Resistance				330		$m\Omega$
Vcc Voltage	VCC	VCC = 3.7V	3.1		3.3	V
Battery Input Standby Current	I_{STB1}	VIN=0V, VBAT=3.7V	15	20	25	μA
IO Driving Current	I_{Gpio}		4	6	8	mA
Light Load Shut Down Detect Time	T_{loadD}	Load current less than 4mA	5	6	7	s
Light Load Shut Down Current	I_{plout}	VBAT=3.7V, The load current of both headphones must be less than I_{plout} to shut down.	3	4	5	mA
Short Press On Key Wake Up Time	$T_{OnDebounce}$		100		300	ms
Long Press On Key Wake Up Time	$T_{Keylight}$		2		3	s
Thermal Shut Down Temperature	T_{OTP}	Rising temperature	130	140	150	$^{\circ}C$
Thermal Shut Down Hysteresis	ΔT_{OTP}		30	40	50	$^{\circ}C$

9. Function Description

System Diagram

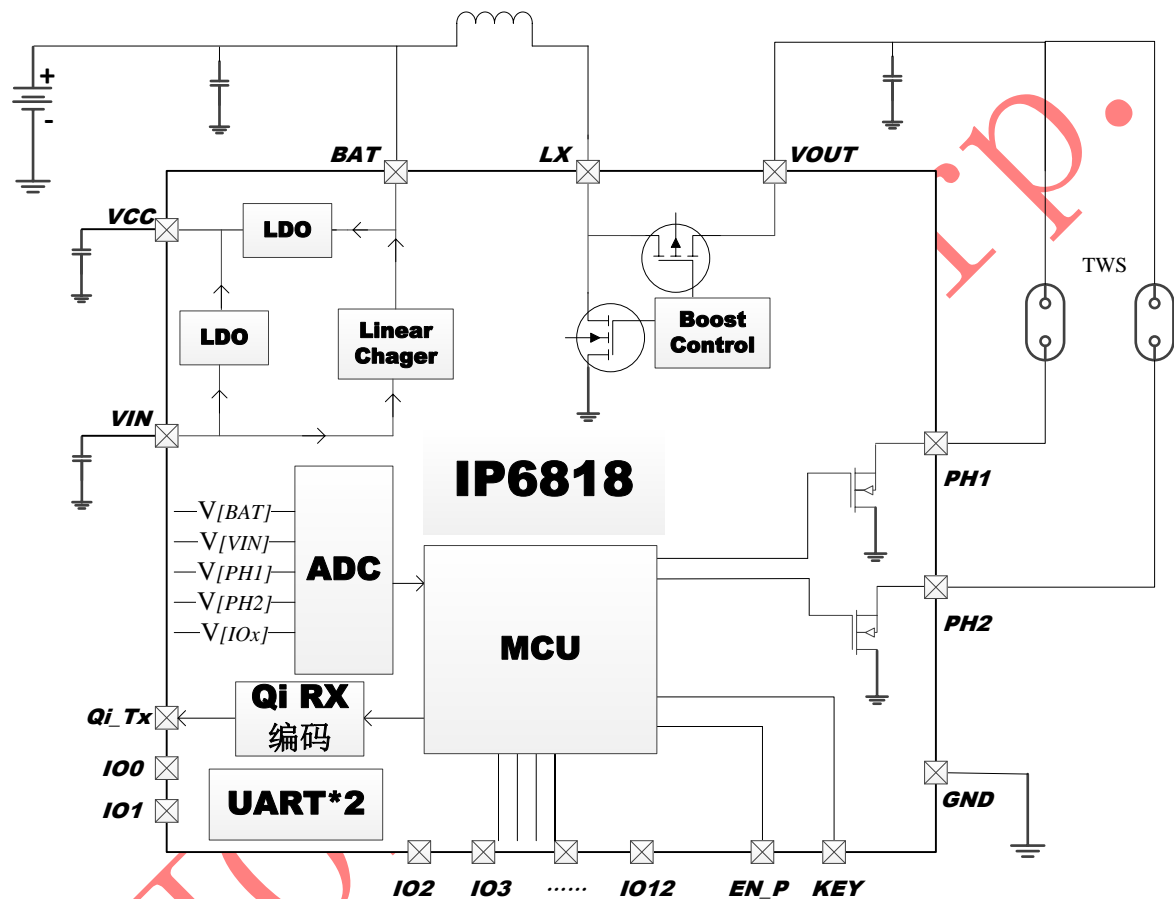

Figure 3 IP6818 Internal System Diagram

Boost

IP6818 integrates a boost dc-dc converter with 5V/300mA output, 1.5MHz switching frequency. To avoid large rush current causing device failure, it is built in overcurrent, short circuit, overvoltage and over temperature protection function, ensuring the reliability and stability of system operation.

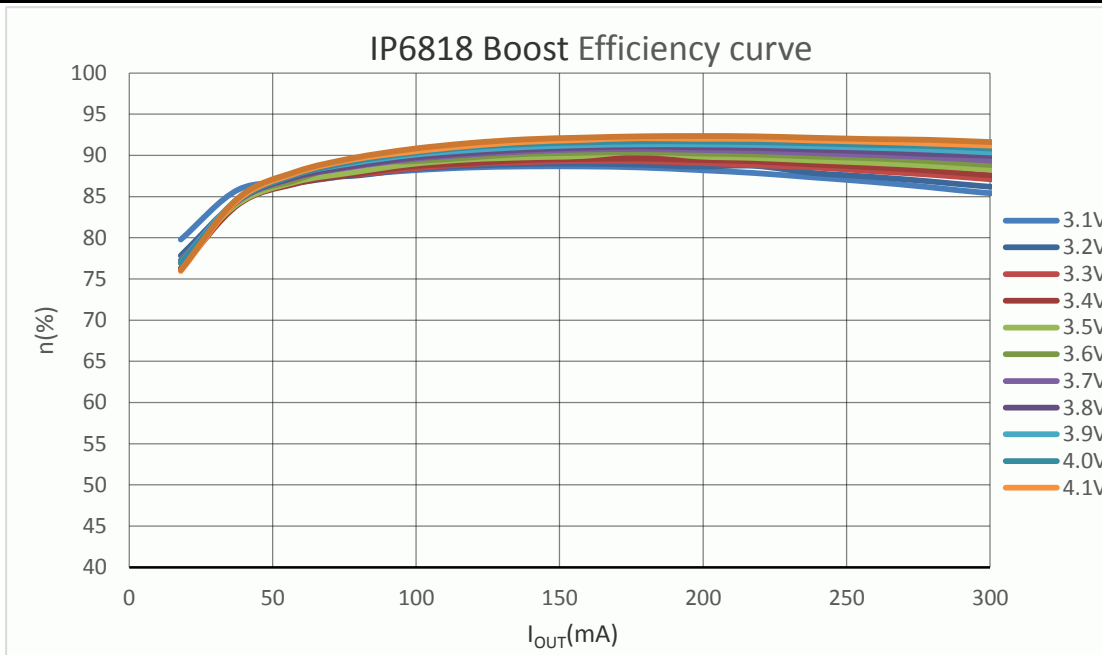

Figure 4 IP6818 Boost Efficiency Curve

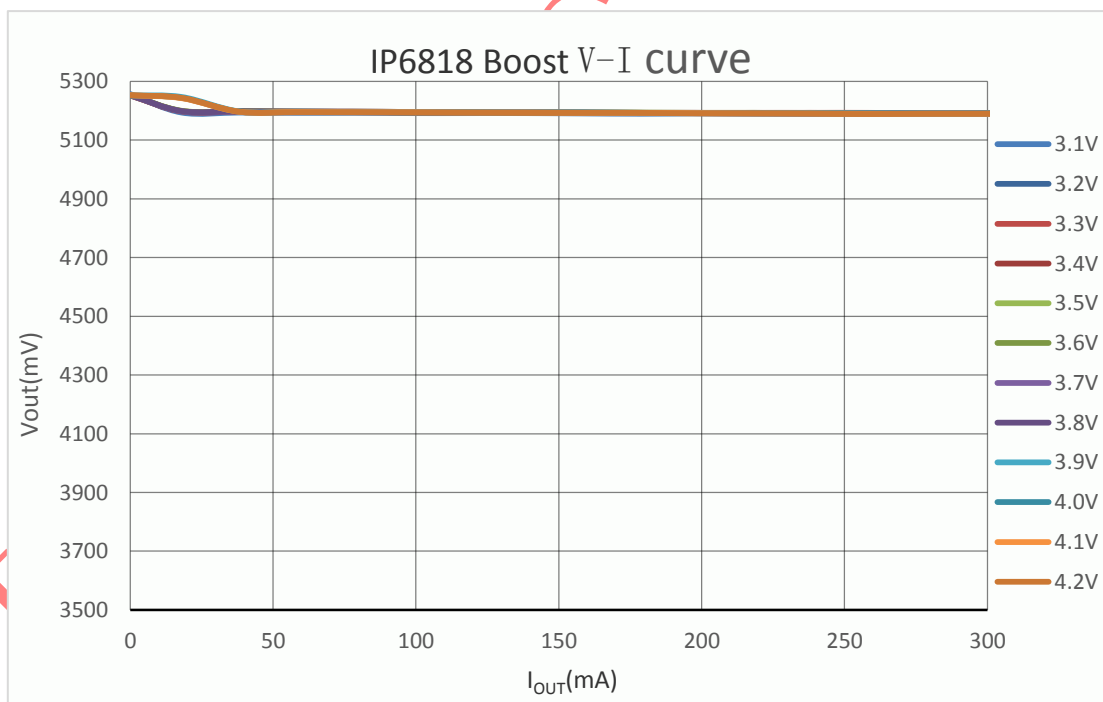

Figure 5 IP6818 Boost Output V-I Curve

Charge

IP6818 integrates a linear lithium battery charger. When the battery voltage is less than 3V, precharge with 0.1 CC; when the battery voltage is greater than 3V, enter constant current(CC) charging; when the battery voltage is close to 4.2V/4.3V/4.35V/4.4V, enter constant voltage charging. When the charging is accomplished, once the battery voltage falls under 4.1V, battery charging stage will be restarted.

IP6818 supports max 500mA charging, with change of the IC temperature and input voltage, IP6818 can intelligently adjust charging current.

IP6818 has built-in power path management. When the battery voltage is greater than 3.3V, it supports discharging while charging; when the battery voltage is less than 3.1V, it does not support discharging while charging, and gives priority to battery charging.

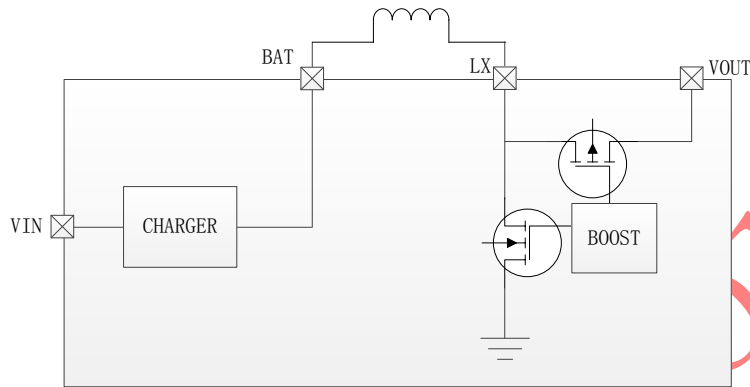

Figure6 IP6818 Power Path Diagram

Qi wireless power receive charging

IP6818 supports the Qi protocol wireless charging reception function. The resonant capacitor of the wireless receiving function needs to be adjusted according to the coil inductance. Please contact INJOINIC Support Department directly.

When the device is wired charging and put on the wireless charging TX, the IP6818 preferentially uses wired charging, and the wireless charging receiving function is actively turned off.

Coulombmeter and battery level display

IP6818 has a built-in power algorithm, which can accurately display the remaining battery power according to the cell capacity.

IP6818 can support 1/2/3/4 LED battery indicator, and the system can automatically identify several LED modes.

IP6818 can also support other power displays such as breathing lights and 188 digital tubes. Such special lights need to be customized separately. Please contact INJOINIC technical support department.

LED light display mode

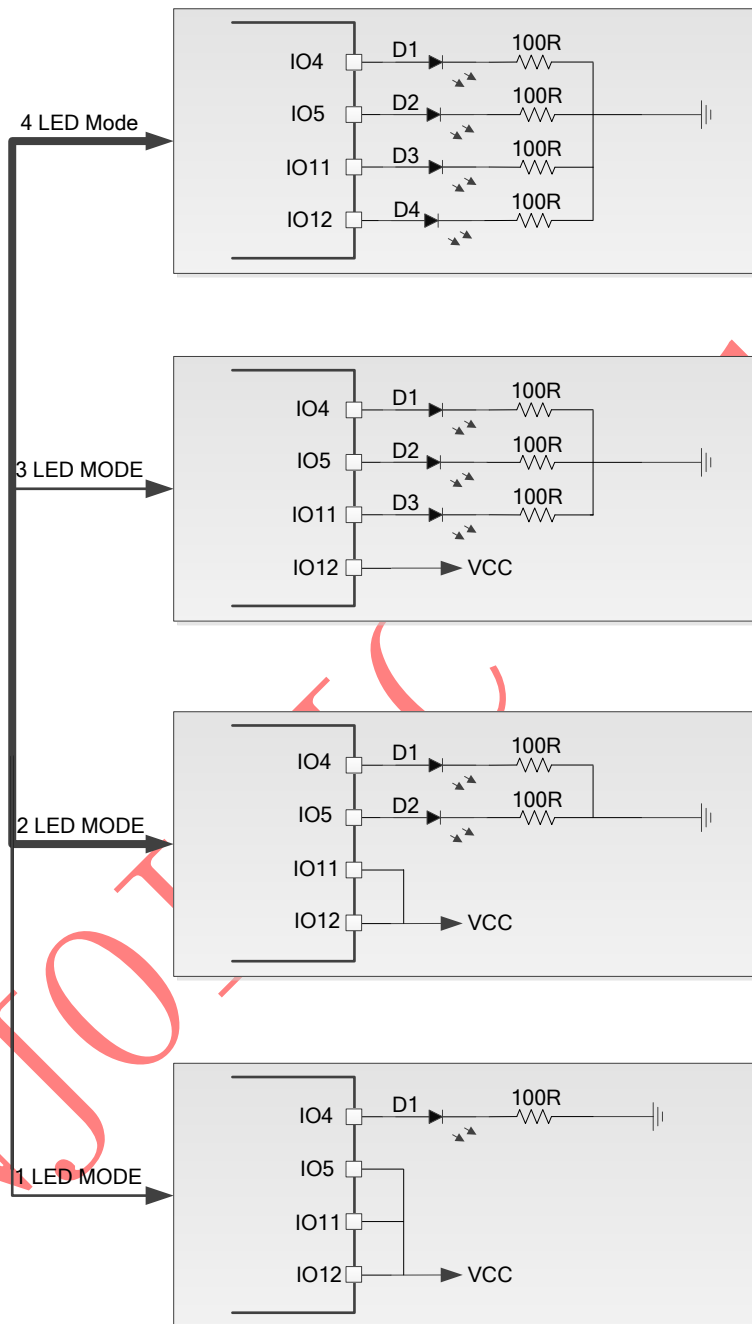

Figure 7 LED Mode Selection Circuit

■ 4 LED Mode

Discharge

Battery capacity(c)(%)	LED1	LED2	LED3	LED4
$C \geq 75\%$	on	on	on	on

$50\% \leq C < 75\%$	on	on	on	off
$25\% \leq C < 50\%$	on	on	off	off
$3\% \leq C < 25\%$	on	off	off	off
$0\% < C < 3\%$	1Hz blink	off	off	off

Charge

Battery capacity(c)(%)	LED1	LED2	LED3	LED4
full	on	on	on	on
$75\% \leq C$	on	on	on	0.5Hz blink
$50\% \leq C < 75\%$	on	on	0.5Hz blink	off
$25\% \leq C < 50\%$	on	0.5Hz blink	off	off
$C < 25\%$	0.5Hz blink	off	off	off

■ 3 LED Mode

Discharge

Battery capacity(c)(%)	LED1	LED2	LED3
$C \geq 66\%$	on	on	on
$33\% \leq C < 66\%$	on	on	off
$3\% \leq C < 33\%$	on	off	off
$0\% < C < 3\%$	1Hz blink	off	off

Charge

Battery capacity(c)(%)	LED1	LED2	LED3
$75\% \leq C$	on	on	on
$66\% \leq C < 100\%$	on	on	0.5Hz blink
$33\% \leq C < 66\%$	on	0.5Hz blink	off
$C < 33\%$	0.5Hz blink	off	off

■ 2 LED Mode

	state	LED1	LED2
charge	charging	0.5Hz 闪烁	off
	full	on	off
discharge	dischargeing	off	on
	low	off	1Hz blink

■ 1 LED Mode

	state	LED1
charge	charging	0.5Hz blink
	full	on
discharge	dischareging	on
	low	1Hz blink

NTC

IP6818 support NTC function used for battery temperature detection. NTC pin outputs 20uA current then detects the voltage on NTC resistance to determine the present battery temperature.

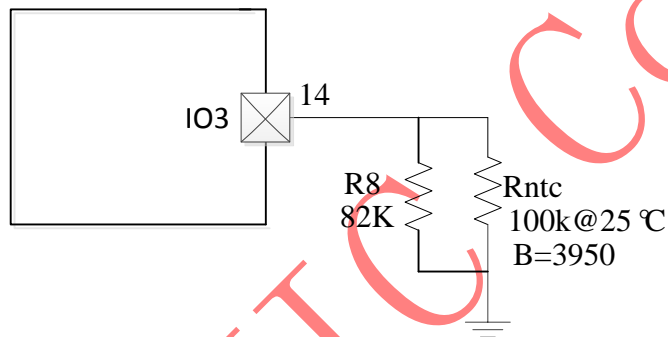

Figure8 NTC circuit

Under charging state:

Voltage on NTC resistance is higher than 1.3V meaning the battery temperature is under 0 centigrade, then stop charging the battery;

Voltage on NTC resistance is lower than 0.5V meaning the battery temperature is above 50 centigrade, then stop charging the battery;

Under discharging state:

Voltage on NTC resistance is higher than 1.47V meaning the battery temperature is under -15 centigrade, stop discharging;

Voltage on NTC resistance is lower than 0.44V meaning the battery temperature is above 55 centigrade, stop discharging.

If NTC function is not required in the scheme, the IO3 pin shall be connected 51K to GND. IO3 pin shall not float, otherwise abnormal charging and discharging may be caused.

Plug-in/plug-out detection

Once detecting the insertion of the earphone, the IP6818 wakes up from the standby mode and turns on the boost 5V to charge the earphone, eliminating the button operation and supporting the buttonless mold solution. The IP6818 supports light-load auto standby function. When the earphone's load current on PH1 and PH2 are less than 4mA for 6 seconds, IP6818 will automatically enter standby mode. In the standby mode, the VOUT pin voltage has three configurations: 5V, VBAT, and 2.4V. The standard standby VOUT output voltage is 2.4V, and other

specifications need to be customized separately.

When the earphones are charged end, the IP6818 will enter standby mode and the VOUT output will change to 2.4V. In this case, in order to make the earphones also enter power-saved mode, You need to adjust the resistance R1/R2 on PH1/PH2. Taking PH1 as an example, the adjustment method is as follows:

1. R1 default resistance is 51K
2. If IP6818 can enters standby mode , but the earphone cannot enter the standby mode, then gradually reduce the R1.
3. If IP6818 can enters standby , but it can not be waked up by the earphone's plug-in, then gradually increase the R1.
4. Repeat steps 2/3 until you find a suitable resistor R1, which makes IP6818 can enter standby mode, and the earphone can enter stanby mode, and IP6818 can be waked up by the plug-in of earphone.

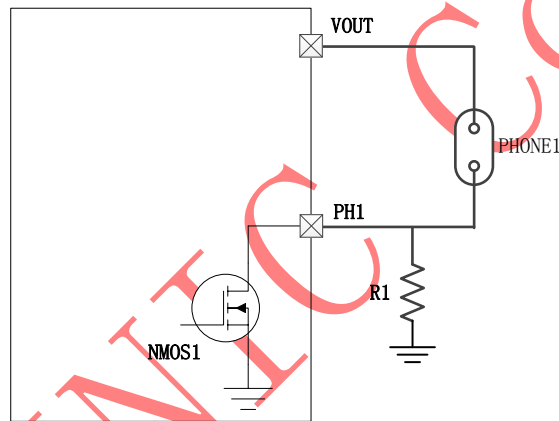
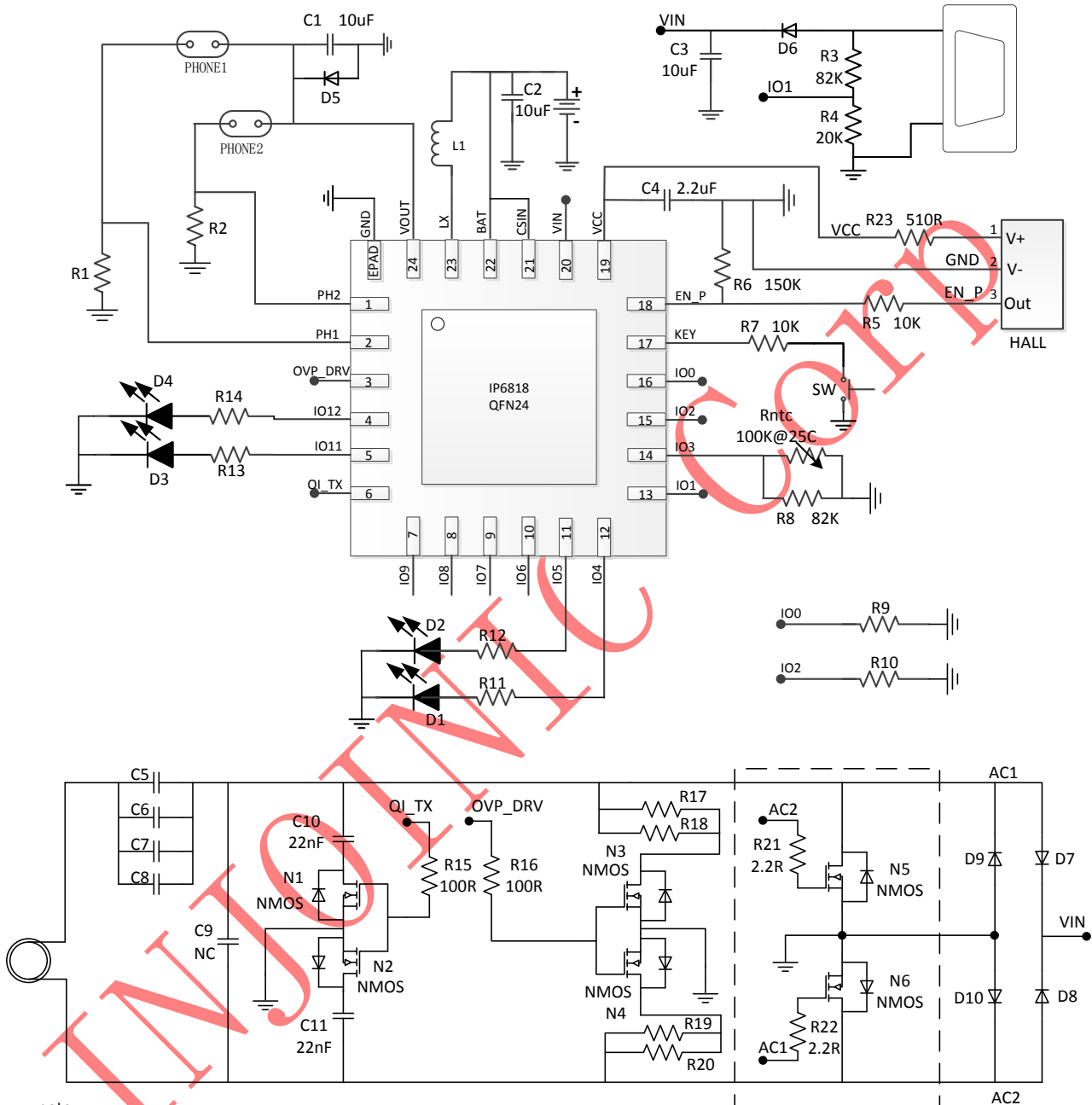

Figure9 IP6818 Earphone Standby Resistance Adjustment Diagram

Earphone communication function

IP6818 supports UART communication function of two independent channels, and can communicate with various earphone solutions.

10. Typical Application Diagram



note:

- 1、R11/12/13/14 Please adjust the resistance value according to the actual LED lamp brightness
- 2、If NTC function is not required, R8 needs to be 51K resistor
- 3、R1/R2 Please adjust the corresponding resistance according to different Bluetooth headset solutions
- 4、N1/N2/N3/N4 need to use NMOS withstand voltage 20V, transient current maximum 5A, constant current 1A
- 5、D5/D6/D7/D8/D9/D10 need to use Schottky diode, constant current 1A
- 6、Please configure C5/C6/C7/C8 according to different coil inductance values
- 7、Please configure R17/R18/R19/R20 according to different coil inductance values
- 8、The D9/D10 can be replaced by NMOS (N5/N6) in the dotted frame to improve the wireless charging efficiency and reduce heat generation
- 9、Please configure R9/R10 according to different coil specifications

Figure10 IP6818 Typical Application Diagram

11. Package

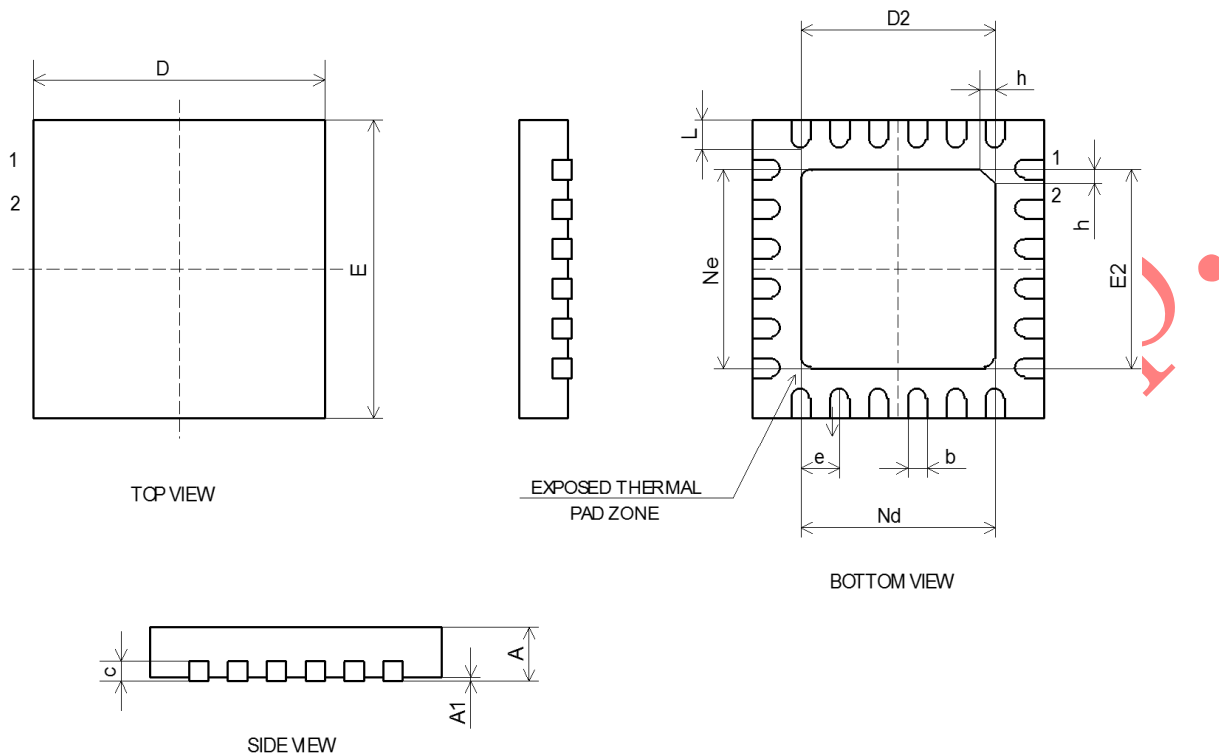

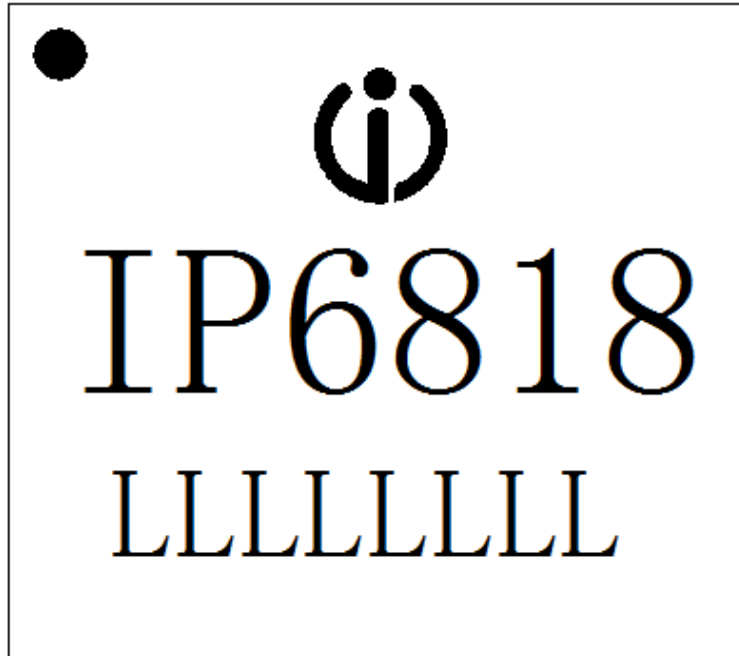

SYMBOL	MILLIMETER		
	MIN	NOM	MAX
A	0.70	0.75	0.80
A1	-	0.02	0.05
b	0.18	0.25	0.30
c	0.18	0.20	0.25
D	3.90	4.00	4.10
D2	2.40	2.50	2.60
e	0.50BSC		
Ne	2.50BSC		
Nd	2.50BSC		
E	3.90	4.00	4.10
E2	2.40	2.50	2.60
L	0.35	0.40	0.45
h	0.30	0.35	0.40

12. Mark description



说明：

- 1、 ——英集芯标志
- 2、IP6818 ——产品型号
- 3、LLLLLLLL——生产批号
- 4、 ——Pin 1脚位置标识

IMPORTANT NOTICE

INJOINIC TECHNOLOGY and its subsidiaries reserve the right to make corrections, enhancements, improvements and other changes to its semiconductor products and services. Buyers should obtain the latest relevant information before placing orders and should verify that such information is current and complete. All semiconductor products (also referred to herein as “components”) are sold subject to INJOINIC TECHNOLOGY's terms and conditions of sale supplied at the time of order acknowledgment.

INJOINIC TECHNOLOGY assumes no liability for applications assistance or the design of Buyers' products. Buyers are responsible for their products and applications using INJOINIC TECHNOLOGY's components. To minimize the risks associated with Buyers' products and applications, Buyers should provide adequate design and operating safeguards.

Buyer acknowledges and agrees that it is solely responsible for compliance with all legal, regulatory and safety-related requirements concerning its products, and any use of INJOINIC TECHNOLOGY's components in its applications, notwithstanding any applications-related information or support that may be provided by INJOINIC TECHNOLOGY. Buyer represents and agrees that it has all the necessary expertise to create and implement safeguards which anticipate dangerous consequences of failures, monitor failures and their consequences, lessen the likelihood of failures that might cause harm and take appropriate remedial actions. Buyer will fully indemnify INJOINIC TECHNOLOGY and its representatives against any damages arising out of the use of any INJOINIC TECHNOLOGY's components in safety-critical applications.

Reproduction of significant portions of INJOINIC TECHNOLOGY's information in INJOINIC TECHNOLOGY's data books or data sheets is permissible only if reproduction is without alteration and is accompanied by all associated warranties, conditions, limitations, and notices. INJOINIC TECHNOLOGY is not responsible or liable for such altered documentation. Information of third parties may be subject to additional restrictions.

INJOINIC TECHNOLOGY will update this document from time to time. The actual parameters of the product may vary due to different models or other items. This document voids all express and any implied warranties.

Resale of INJOINIC TECHNOLOGY's components or services with statements different from or beyond the parameters stated by INJOINIC TECHNOLOGY for that component or service voids all express and any implied warranties for the associated INJOINIC TECHNOLOGY's component or service and is an unfair and deceptive business practice. INJOINIC TECHNOLOGY is not responsible or liable for any such statements.